

DEVON BED FRAME - SINGLE

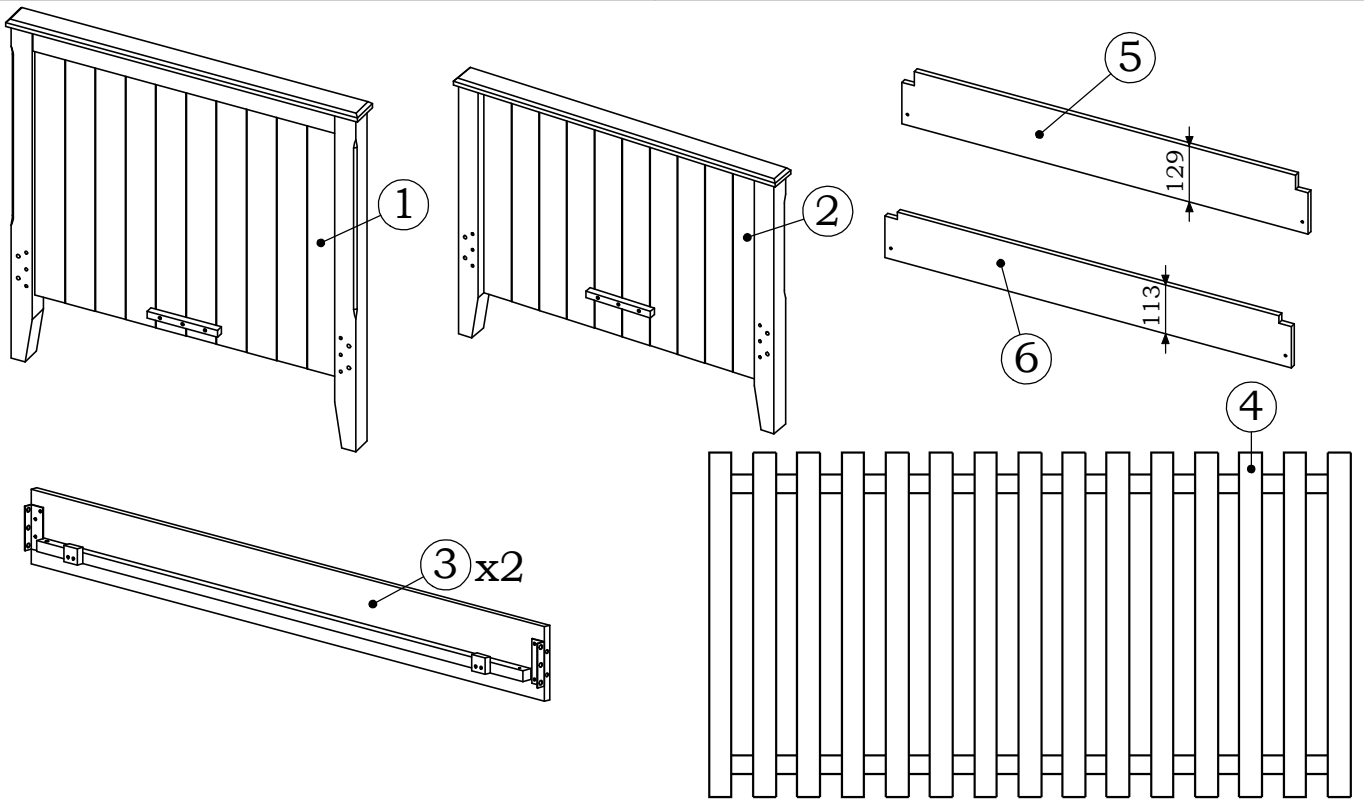

STEP 1

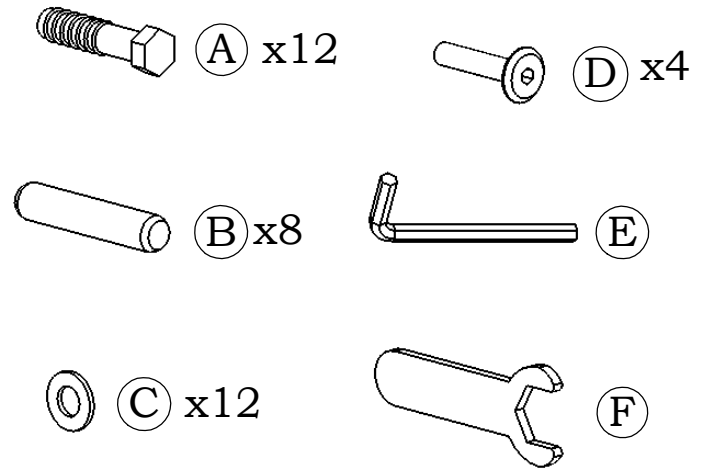
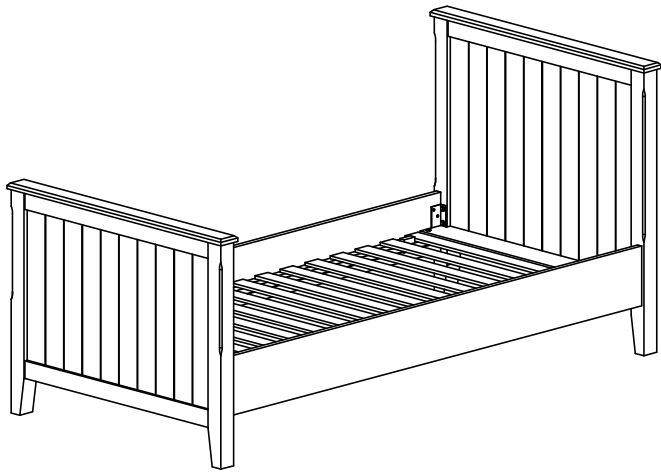
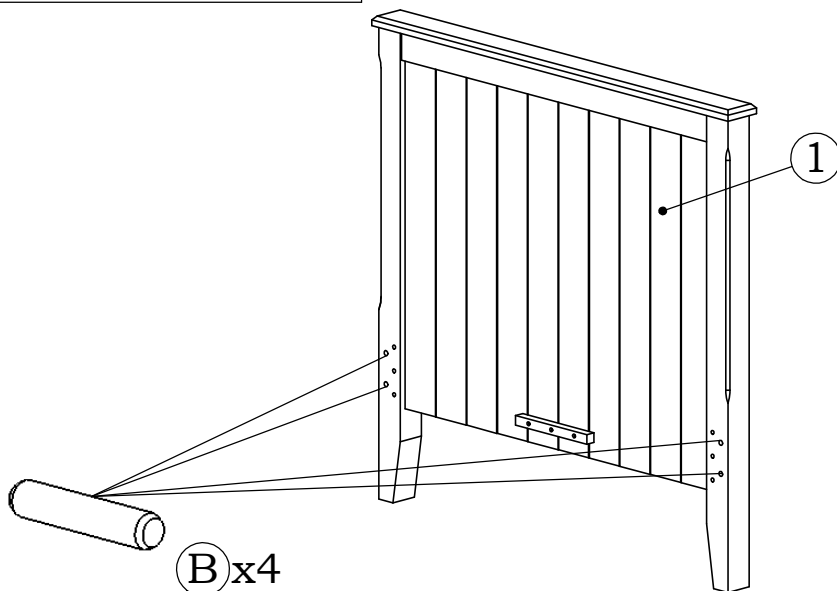
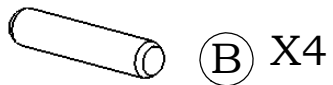

STEP 2

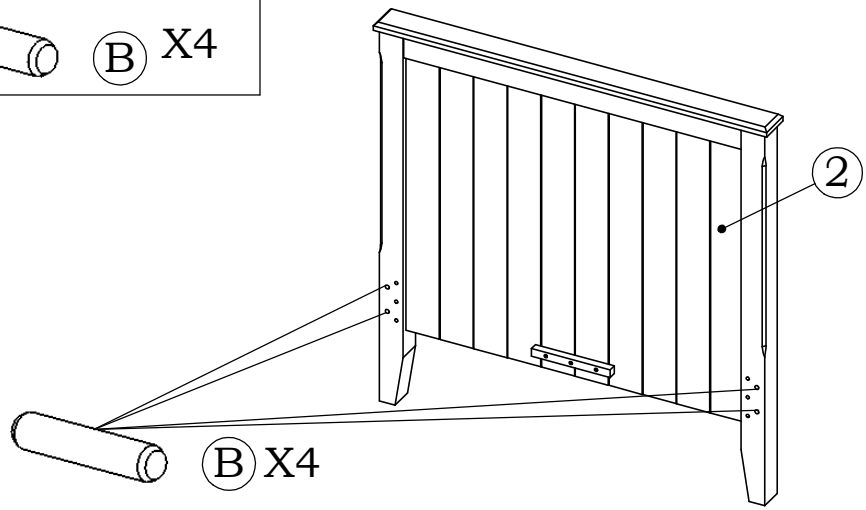
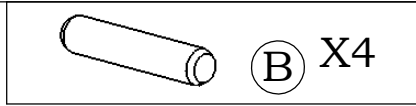

STEP 3

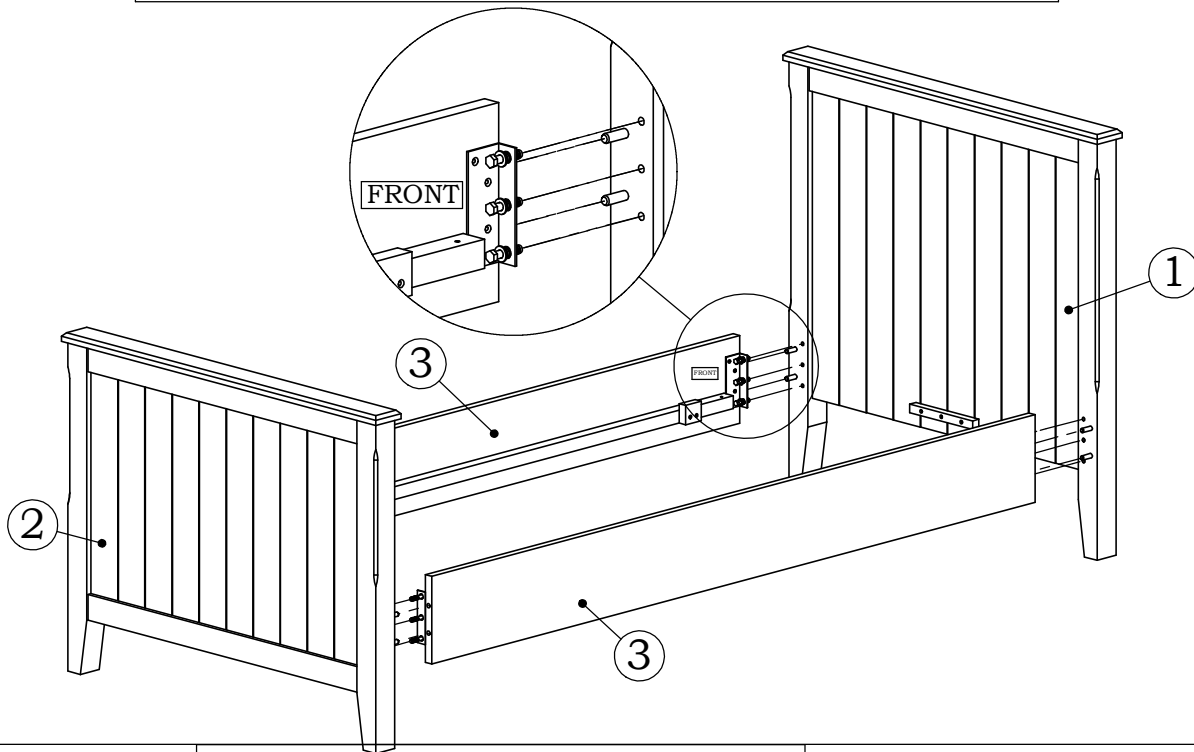
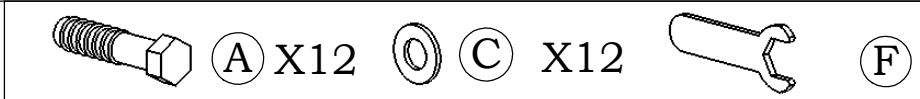

STEP 4

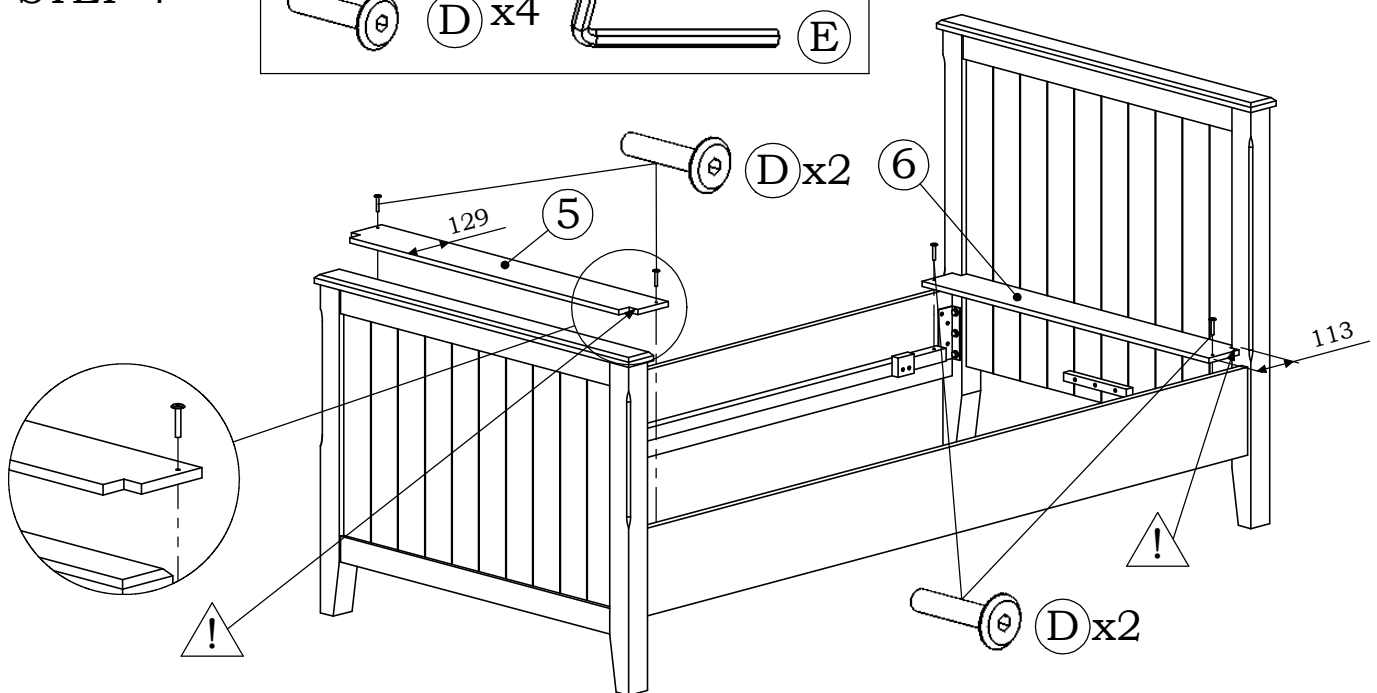
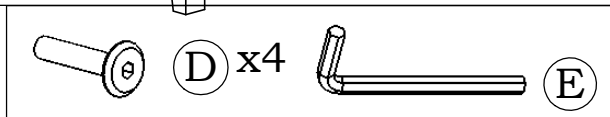

STEP 5.1

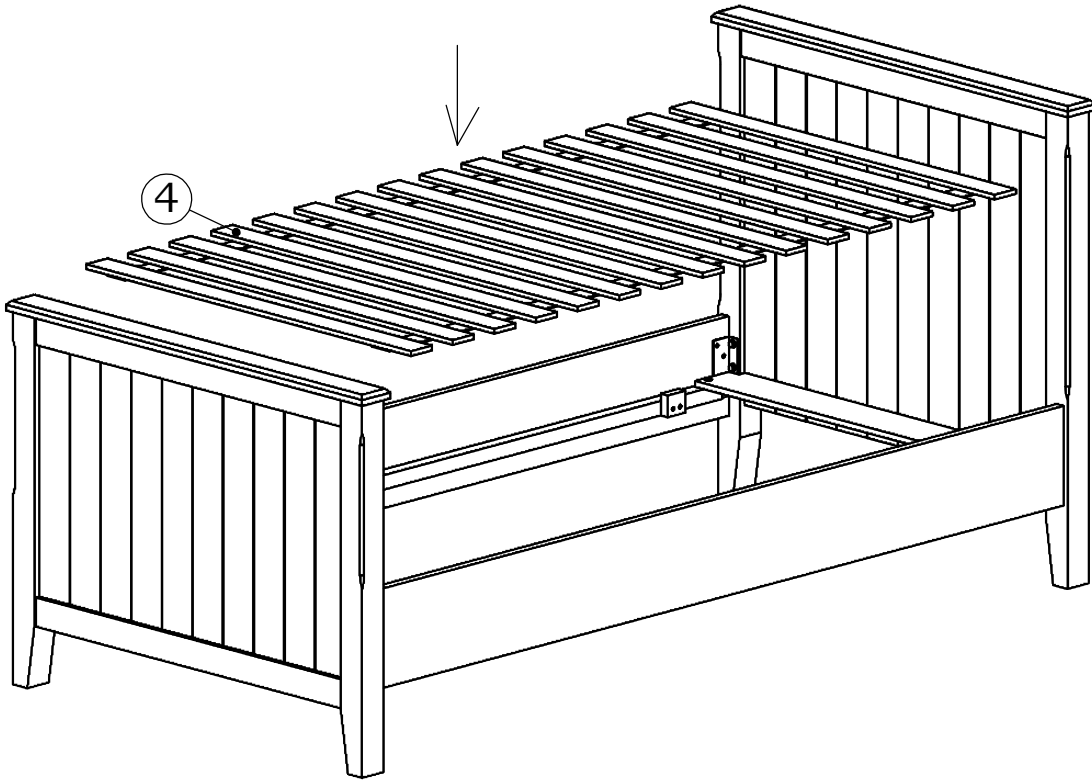

STEP 5.2

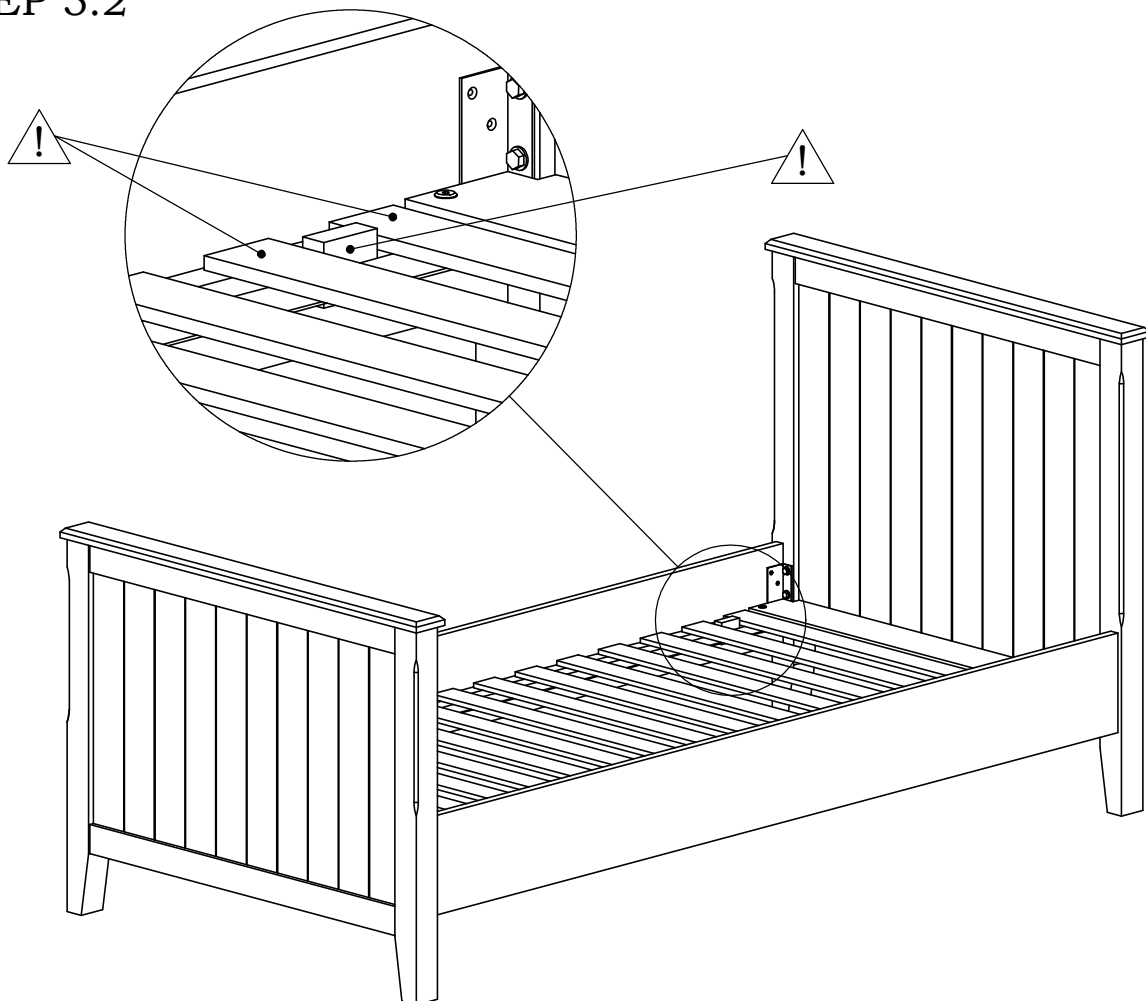

Important - Retain these instructions for future reference

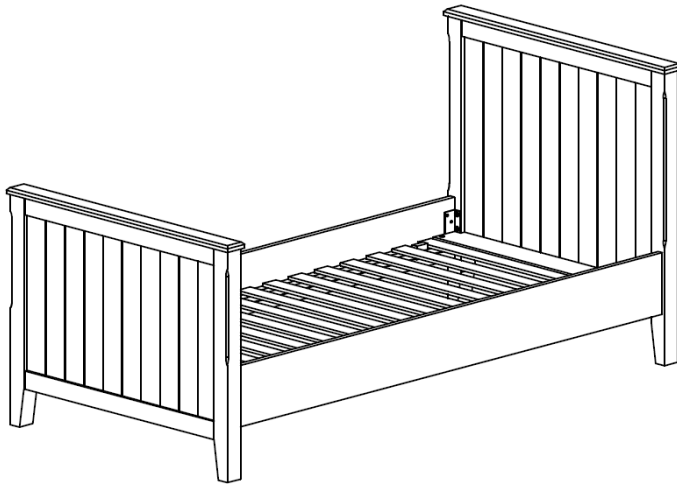

The bed conforms to BS 8509:2008.

IMPORTANT! KEEP INSTRUCTIONS FOR FUTURE USE



WARNING:

Failure to follow these warnings and assembly instruction could result in serious injury or death.

- Bed for use by one child aged over 4 years DO NOT USE FOR INFANTS.
- Read all instructions before assembling bed.
- Hardware contains small screws with sharp points. Keep unassembled parts out of the reach of small children.
- Before each usage or assembly, inspect the bed for damaged hardware, loose joints, missing parts or sharp edges. All assembly fittings should always be tightened properly and checked periodically.
- DO NOT use the bed if any parts are missing or broken.
- Do not substitute parts, contact the manufacturer or distributor for replacement parts.
- The mattress intended for use on the bed shall be a full-size crib mattress having minimum dimensions of 1900 mm in length and 900 mm in width and 200-250 mm in thickness.
- Always use the recommended size mattress or mattress support, or both, to help prevent the likelihood of entrapment or falls.
- Children are likely to play, bounce, jump and climb on beds, therefore the child's bed should not be placed too close to other furniture or windows, and should be placed either tight to any wall or have a gap 300mm between the wall and the side of the bed.
- Do not place this bed near heat sources.

CARE INSTRUCTIONS:

- Dust often using a soft, dry cloth or clean the surface using slightly damp cloth and mild washing liquid if necessary
- Do not use any chemical cleaners or polishes, abrasives, wax or household cleaners.
- If refinishing, use a non-toxic finish specified for children's products